

O-RING JOINT DETAIL
(MEETING ASTM SPEC. 443)
JOINTS MUST BE KEPT TO A MINIMUM

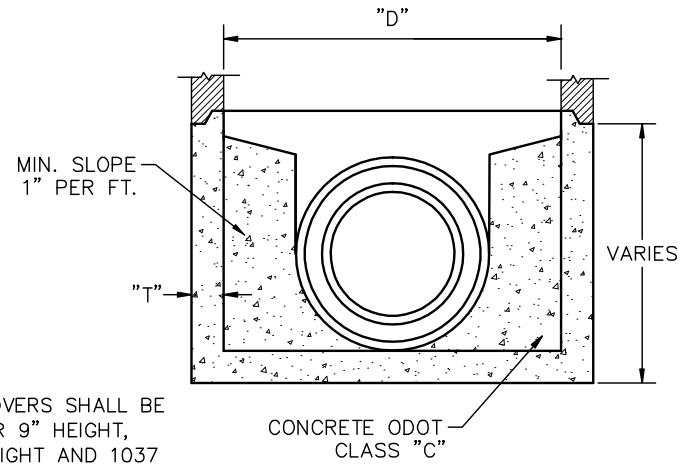

PRECAST BASE SECTION

NOTES

- A.** SANITARY MANHOLE FRAMES AND COVERS SHALL BE EAST JORDAN IRON WORKS NO. 1050 FOR 9" HEIGHT, 1020 FOR 6" HEIGHT, 1022-1 FOR 7" HEIGHT AND 1037 FOR 4" HEIGHT, WITH TYPE "A" SOLID COVER LID. WATERTIGHT MANHOLES SHALL BE THE EQUAL TO NEENAH NO. R-1916-D OR EAST JORDAN IRON WORKS NO. 1600-PT. NO LATERALS SHALL PROTRUDE INTO THE INTERIOR MANHOLE. COVER LID SHALL BE MARKED "SANITARY" AND SHALL HAVE AN O-RING GASKETED SEAL.
- B.** TO CONNECT INTO EXISTING MANHOLE, THE MANHOLE SHALL BE CORED AND AN A-LOK XP SERIES FLEXIBLE CONNECTOR OR EQUIVALENT SHALL BE INSTALLED PER MANUFACTURER'S RECOMMENDATIONS. NON-SHRINK GROUT ALTERNATIVE MAY BE USED IN SPECIAL CIRCUMSTANCES WHEN PREVIOUSLY **APPROVED BY VILLAGE.**
- C.** MATERIALS FOR BASES, RISERS, AND OTHER PRECAST SECTIONS, INCLUDING REINFORCEMENTS SHALL COMPLY WITH ASTM C-478.
- D.** MAXIMUM SANITARY MANHOLE SPACING SHALL BE 400'.
- E.** LOCATE THE CENTERLINE OF MANHOLE COVERS OVER THE CENTERLINE OF THE MAIN SEWER WHENEVER POSSIBLE.
- F.** CONSEAL CS-102 FLEXIBLE BUTYL RESIN SEALANT OR EQUIVALENT SHALL BE 3/8" X 1" MINIMUM STRIPS UNDER GRADE RINGS AND CASTING.
- G.** CUT PIPE SHALL NOT EXCEED BEYOND THE INSIDE FACE OF THE MANHOLE WALL.
- H.** CONCRETE PLACED INSIDE THE MANHOLE SHALL NOT BE PLACED BETWEEN THE PIPE AND THE OPENING SO AS TO INTERFERE IN ANY WAY WITH THE FLEXIBILITY OF THE JOINT.
- I.** MANHOLES IN PAVEMENT SHALL HAVE CHIMNEYS CONSTRUCTED ACCORDING TO SHEET 500-7,500-8 AND 500-9.

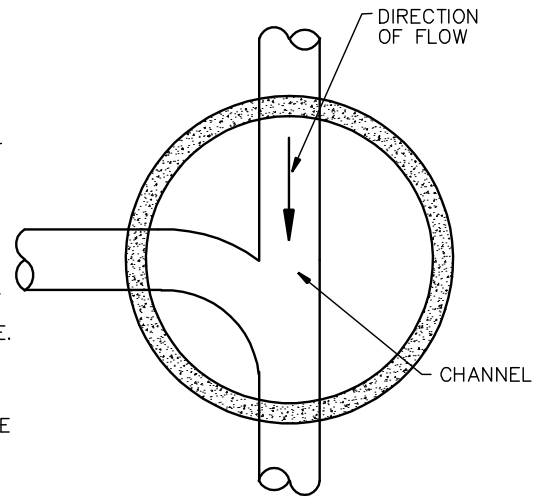

STANDARD INVERT CHANNEL

ALL INVERTS TO BE CHANNELED FOR OPTIMUM FLOW.

PIPE SIZE	T	D
24" & UNDER	5"	48"
27" & ABOVE	6"	60"

VILLAGE OF
ADA

TYPE 3 SANITARY MANHOLE

REVISIONS: AUG. 1999 MAR. 2000 04-09-09	DATE APPROVED: MAY 1997 PAGE No. 900-1
--	--